

## Elite Optima Kneading and Tapping Motor troubleshooting

For questions, clarifications or assistance call 800-592-0548 x 1

The use of this procedure is to troubleshoot the cause of either a kneading or tapping function not working on the massage chair.

After swapping the power sources to the kneading motor and tapping motor, you will then test the kneading button on remote to determine if the tapping function works and the tapping button on the remote to determine if the kneading function works:

If the original failed function (kneading or tapping) still does not work, then there is a motor failure.

If original failed function (kneading or tapping) now works and alternate function does not – there is a power electronic/board assembly failure

*Tools required One # 2 Phillips screw driver*

***BEFORE BEGINNING, turn the power switch on the chair off and unplug the power cord. Allow the chair to sit for 10 minutes before proceeding.***

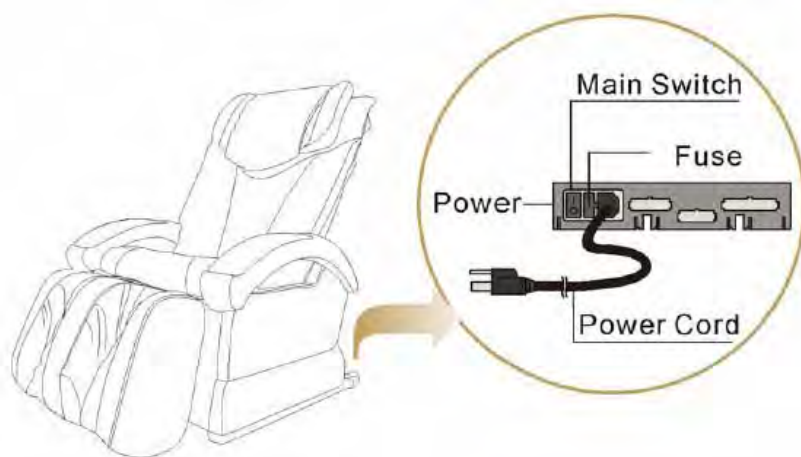

**Step 1:** Lay the back of the chair down over the seat of the chair.



Reach under the back of the chair with your right hand.....about 6” in from the left side and about 4” in from the back cover. Locate the latch mechanism with a finger and pull latch out to release.



CAUTION, when the latch is released, the back will be free weight and will pivot. Hold the top of the chair and lay forward gently.



Hold onto the seat back until it is firmly lying on the seat.  
*DO NOT ALLOW chair back to 'drop' unsupported onto the seat.*

**Step 2:** Once the back of the chair is folded down and you are ready to begin, locate the six screws holding the back cover on. Disconnect the two air hoses in the upper left corner of cover as shown with arrow below. Using your # 2 Phillips screw driver remove the six screws. Lift the back cover up and off and set aside.



**Step 3:** Locate the expansion board in the backrest just right of the kneading motor.

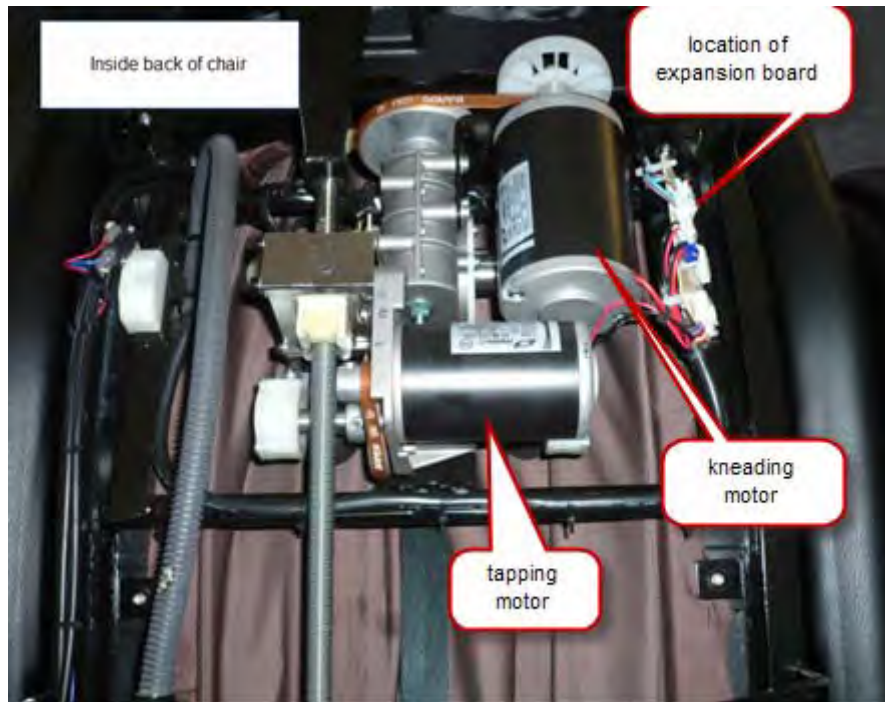

**Step 4:** Locate the K and T connectors on the expansion board. Disconnect each and put back onto the opposite connector so that the connector that was originally on T will now be on K and K will now be on T.

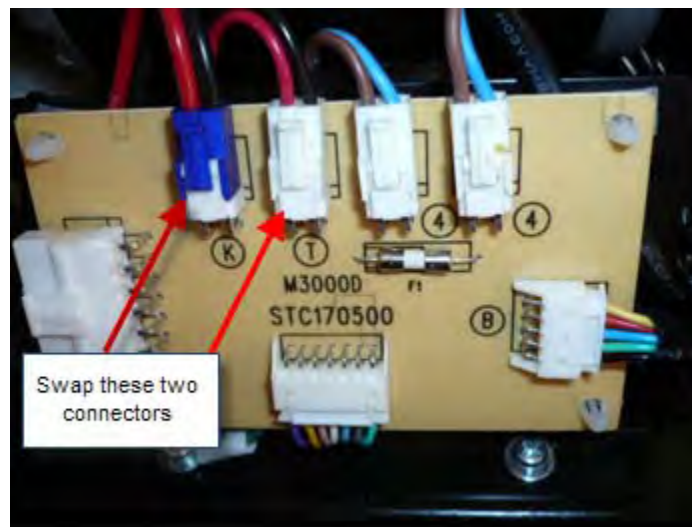

**Step 5:** Plug chair back into outlet and turn main switch on. Then, using the remote control for the chair, turn the chair on, press the manual button and then push the tapping button once. Make a note whether the massage arms are kneading or not. Press the tapping button again to stop kneading.



**Step 6:** Using the remote control for the chair, now press the kneading button. Make a note whether the massage arms are tapping or not. Press the kneading button again to stop tapping.



Step 7: Report results to Elite massage chair customer support at 1-800-592-0548 x 1