

Optima Footrest and Backrest Recline Troubleshoot
For questions, clarifications or assistance call 800-592-0548 x 1

Tools required: Phillips head screwdriver

Step 1): Lock the leg rest assembly up. This will allow increased access to the working area.



...use your left hand to push the locking mechanism (square tubing) up. Release your hold on the leg rest assembly. The entire assembly should remain up for better access to the work area. (After completion of the entire task, lower the leg-rest by simply lifting the entire assembly up which will automatically release the lock).

Step 2) Remove vanity panel cover.

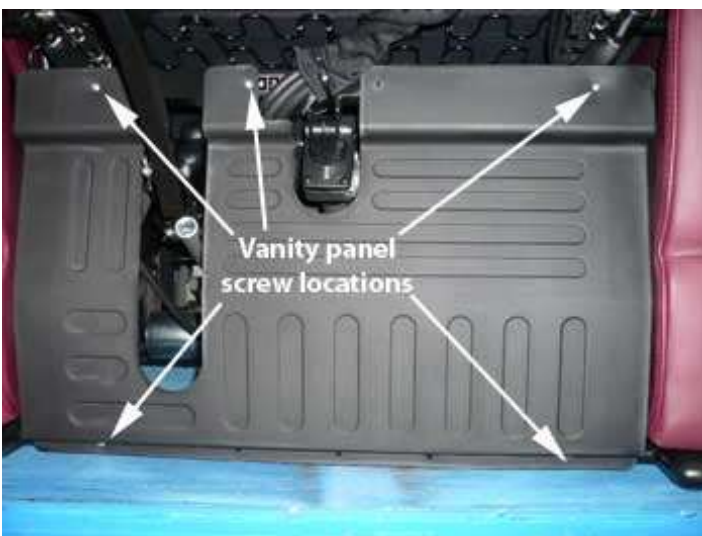

Step 3) Remove expansion board cover. Expansion board is located in the upper right corner behind vanity panel.



The circuit board will look like this.

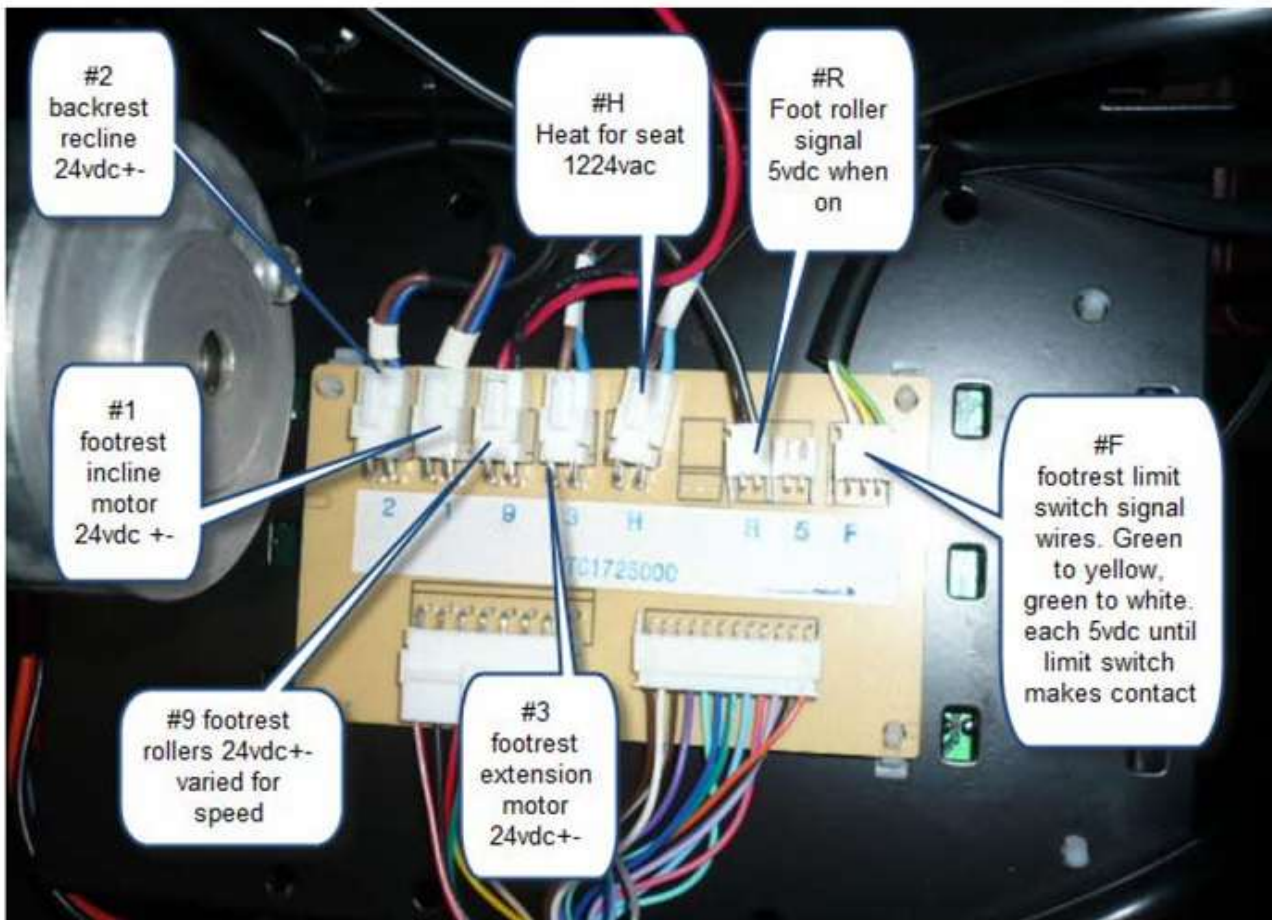

Step 4) Disconnect wires 1 & 2 located in the top left corner and connect wire 1 to terminal 2 on the board and wire 2 to terminal 1 on the board.

The footrest controls on the remote control will now operate the backrest and the backrest controls will now operate the footrest.

Step 5) Please attempt to move both the footrest and the backrest controls up and down and note what happens.

- If the part of the chair (footrest or backrest) that was NOT moving up and down before now works, you will need a new main board assembly. Please contact Elite Massage Chairs for further instructions.
- If the part of the chair (footrest or backrest) that was NOT moving up and down before still does not work, you will need a new footrest/backrest motor. Please contact Elite Massage Chairs for further instructions.
- **After troubleshooting and diagnosing issue please remember to plug 1 and 2 wires back into their original ports.**